

Press-On Conical

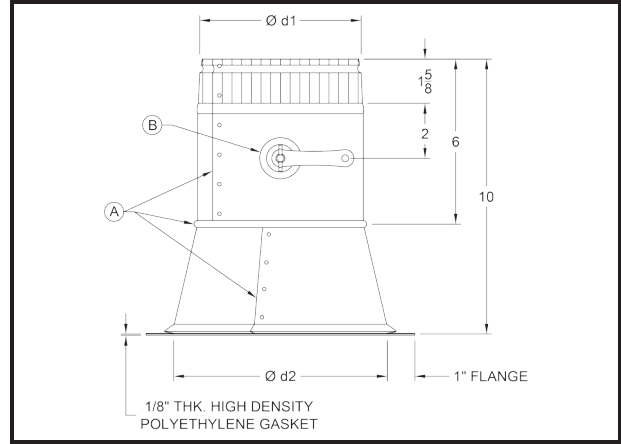

Technical Data

- GSI Conicals are designed and tested to surpass SMACNA Class 3 Leakage Standards.*
 - Pre-sealed with gasket made of EPDM rubber and proprietary co-polymer
 - Zero VOCs
 - Galvanized Steel (ASTM A653 and A924)
 - G-60 Galvanized Coating (ASTM A653 and ASTM A90)
 - Available in Specialty Metals:
 - G-90 Galvanized Steel
 - Aluminum (ASTM B209 Alloy 3003 Temper H14)
 - 304 Stainless Steel (ASTM A480 2B Finish)
 - Pressure Rating: Designed per SMACNA Third Edition 2005 Section 4.8 Figure 4-6 Branch Connections
 - Dimensional Tolerance: $\pm 1/4$ "
- A. Conicals now come standard with sealed joints! The riveted seam on the collar and boot, as well as the co-latch seam between the collar and boot are sealed with the GreenSeam integral gasket. Unsealed fittings are available upon request.
- B. Non-dampered conicals are supplied with a 3/8" knock-out. Dampered conicals are supplied with 24GA. damper blades and GSI's proprietary low-leakage hardware. See Appendix A.

Product Availability

Size (Ød1)	Gauge Availability		Quantity		Dimension
	26 Ga.	24 Ga.	Carton	Skid	Ød2
4"	Yes	-	20	200	5 3/4"
5"	Yes	Yes	20	200	6 3/4"
6"	Yes	Yes	20	160	7 3/4"
7"	Yes	Yes	8	96	8 3/4"
8"	Yes	Yes	8	96	9 3/4"
9"	Yes	Yes	8	96	10 3/4"
10"	Yes	Yes	8	96	11 3/4"
12"	Yes	Yes	5	50	13 3/4"
14"	Yes	Yes	5	50	15 3/4"
16"	Yes	Yes	5	40	17 3/4"
18"	Yes	Yes	A/O	A/O	19 3/4"
20"	Yes	Yes	A/O	A/O	21 3/4"

Dampered fittings are available with 1 1/2" or 2" Stand-Off. See Appendix C on page 28.
A/O - As Ordered

Part Number Schematic

Example: **CNS15PR10GA26D38** = Press-on Conical for 10" Pipe in 26Ga. Galvanized Steel, with a Solid Rod Damper and 1 1/2" Stand-Off

S	CN	S15	P	R	10	GA	26	D	C
Scoop (Opt.)	Conical	Stand-Off S15 - 1 1/2" S2 - 2" (Opt. on Dampers Only)	Press-On	Riveted	Conical Diameter (Ød1)	Material GA-Galvanized (Std.) AL - Aluminum S4 - 304 S.S	Gauge GA - 26, 24 AL - 32 S4 - 26	Damper (Opt.)	Wingate hardware 38 3/8" Solid Rod (Opt. on Dampers Only) See Appendix A on page 26.

Items in green denote available options
Check with your sales representative for availability of any size, gauge, or specialty metal item not shown here.
* Test performed on standard fittings without dampers.