

45° Eyelet End Fixing



For the sway bracing of HVAC, Mechanical, Lighting & Electrical services in an indoor stationary setting. NOT suitable for use in chlorinated / swimming pool environments.

APPLICATION / MATERIAL SPECS

For fastening into concrete, steel, or wood for sway bracing of services that are suspended with an existing hanger. Hole is sized for a 3/8" fastener.

MATERIAL

Cable: Galvanized high tensile steel cable to EN12385.

Standard lengths from 5ft-30ft, other lengths can be made to order.

	No. 2	No. 3
Cable Dia. (in.)	5/64"	1/8"
Strand configuration	7x7	7x7

45° Eyelet: Zinc plated steel

* Refer to fastener load ratings and safety factors.

45° EYELET

Cable with crimped 45° Eyelet end fixing*



SIZE SPECS

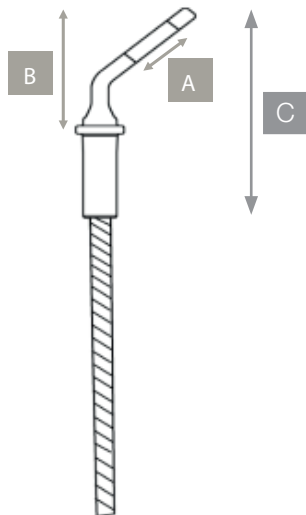

Size	A (in.) Anchor Size Ø	B (in.)	C (in.)
No. 2	3/8"	1 1/8"	2 1/16"
No. 3	3/8"	1 1/8"	2 1/16"

APPLICATION EXAMPLE

Applicable for use with all types of suspended services.

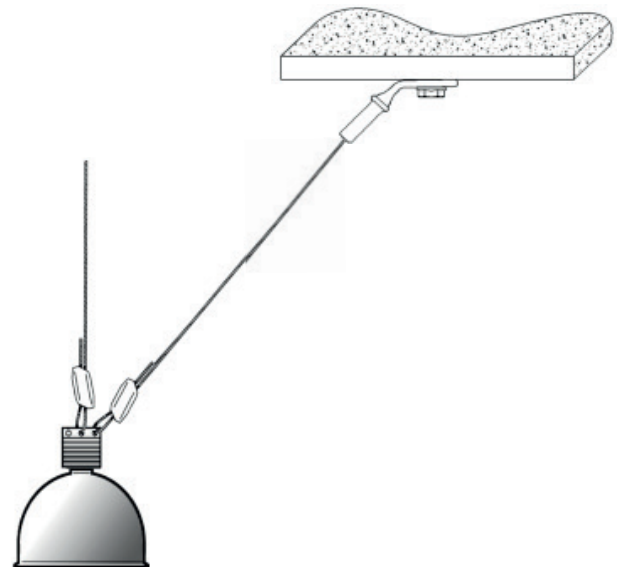

PI-45 EYELET-US
Digital AUG 2022

www.gripple.com

Gripple's policy is one of continuous development and innovation. We therefore reserve the right to alter specifications, etc. without notice.



Gripple Inc | 1611 Emily Lane | Aurora, IL 60502 | USA

Tel +1 866 474 7753 Fax +1 800 654 0689 Email grippleinc@gripple.com